



Precast/Prestressed Concrete Institute

# Envelope Tolerances For Architectural Precast



designer'snotebook

# ENVELOPE TOLERANCES FOR ARCHITECTURAL PRECAST

Designers must recognize that manufacturing and erection tolerances apply to precast concrete just as they do to other building materials. Tolerance is defined as a permissible variation from a specified dimension. A tolerance can be expressed as an additive (+) or subtractive (-) variation from a specified dimension or relation or as an absolute deviation from a specified relation. Tolerances define realistic limits for size and shape within which the precast concrete units must lie, and must satisfy the designer's intent while ensuring the constructability and economy of the building system.

Three groups of tolerances should be established as part of the precast concrete design: product tolerances, erection tolerances, and interfacing tolerances.

Tolerances are established for the following reasons:

1. Structural—To ensure that structural design accounts for variations in production and installation dimensional control. Examples include eccentric loading conditions, bearing locations, hardware anchorage locations, and locations of reinforcing or prestressing steel.
2. Feasibility—To ensure acceptable performance of joints and interfacing materials, such as glazing between panels, and to ensure that designs and details are dimensionally feasible.
3. Visual—To ensure that the variations will result in an aesthetically acceptable structure.
4. Economic—To ensure ease and speed of production and erection with a known degree of accuracy in the dimensions of the precast concrete product.
5. Contractual—To establish a known acceptability range and to establish responsibility for developing, achieving, and maintaining mutually agreed tolerances.
6. Legal—To avoid encroaching on property lines and to establish tolerance standards against which the work can be compared in the event of a dispute.

Tolerances and interface conditions are best handled by the design team, general contractor, or other entity having the contractual authority necessary to specify, coordinate, and control interfacing requirements of other trades that adjoin the precast concrete construction.

While the responsibility for specifying and maintaining tolerances of the various elements may vary among projects, it is important that this responsibility be clearly assigned and communicated to all members of the project team. The tolerances must be reasonable, realistic, and within

generally accepted limits. Some manufacturing and erection costs are directly proportional to the tolerance requirements. It is more economical to design connection and interface details with maximum flexibility and to keep tolerance requirements as realistic as possible.

ACI has adopted the PCI Tolerances as a consensus standard in ACI ITG-7, *"Specification for Tolerances for Precast Concrete"* which is referenced by ACI 301 *"Specifications for Structural Concrete."*

It should be understood by those involved in the design and construction process that the tolerances listed in this publication must be considered as guidelines for an acceptability range and not limits for rejection. If specified tolerances are met, the members should be accepted. If these tolerances are exceeded, the member may still be acceptable if it meets any of the following criteria:

1. Exceeding the tolerances does not affect the structural integrity, architectural performance of the member, or other trades.
2. The member can be brought within tolerance by structurally and architecturally satisfactory means.
3. The total erected assembly can be modified reasonably to meet all structural and architectural requirements.

The enforcement of tolerances should be based on the technical judgment of the designer. This design professional is able to decide whether a deviation from the allowable tolerances affects safety or appearance. In building construction, very little out of tolerance work, whether it is concrete, masonry, cast-in-place concrete, steel, or precast concrete, has been rejected and removed solely because it was "out-of tolerance."

**Product Tolerances** - Product tolerances relate to the dimensions and dimensional relationships of the individual precast concrete units. They are a measure of the dimensional accuracy required on individual members to ensure, prior to delivery, that the members will fit the structure without requiring tolerance related rework. Product tolerances are applied to physical dimensions of units such as thickness, length, width, squareness, and location and size of openings. They are determined by economical and practical production considerations, and functional and appearance requirements. Product tolerances also control the locations of the member features as they relate to the overall member dimensions.

Tolerances for manufacturing are standardized throughout the industry and should not be specified to be more stringent, and therefore more costly, unless absolutely necessary. Areas that might require more exacting tolerances could include special finish or appearance requirements, glazing details, and certain critical dimensions on open shaped units such as C or U shaped panels, and spandrels interspersed with windows.

When a project involves particular features sensitive to the cumulative effect of generally accepted tolerances on individual portions, the design team should anticipate and provide for this effect by setting a cumulative tolerance or by providing clearances where accumulated tolerances or production tolerances can be absorbed. The consequences of each materials tolerances permitted on a particular project should be investigated to determine whether a change is necessary in the design or in the tolerances applicable to the project or individual components. For example, there should be no possibility of minus tolerances accumulating so that the bearing length of members is reduced below the required design minimum. These bearing dimensions and their tolerances should be shown on the erection drawings.

The published allowable variation for one element of the structure should not be applicable when it will permit another element of the structure to exceed its allowable variations.

Restrictive tolerances should be reviewed to ascertain that they are compatible and that the restrictions can be met. For example, a requirement that states, "no bowing, warpage, or movement is permitted," is not practical or possible to achieve.

The product tolerances for architectural precast concrete panels have the following significance:

1. Length or width dimensions and straightness of the precast concrete will affect the joint dimensions, opening dimensions between panels, and possibly the overall length of the structure. Tolerances must relate to unit size and increase as unit dimensions increase.
2. Panels out-of-square can cause tapered joints and make adjustment of adjacent panels difficult.
3. Thickness variation of the precast concrete unit becomes critical when interior surfaces are exposed to view. A non-uniform thickness of adjacent panels will cause offsets of the front or the rear faces of the panels.

Industry product tolerances for architectural precast concrete panels are defined as follows:

Warping is generally the twisting of a member, resulting in an overall out-of-plane curvature in which the corners of the panel do not all fall within the same plane. Warping tolerances are stated in terms of the magnitude of the corner variation, usually the allowable variation per 1 ft (0.3 m) of distance from the nearest adjacent corner with a not-to-exceed maximum value of corner warping.

Bowing is an overall out-of-plane curvature, which differs from warping in that while the corners of the panel may fall in the same plane, the portion of the panel between two parallel edges is out of plane. Differential temperature effects, differential moisture absorption between the inside and outside faces of a panel, the effects of prestress eccentricity, and differential shrinkage between wythes in an insulated panel should be considered in design to minimize bowing and warping.

Panel Dimensions <sup>1</sup>	8 ft	10 ft	12 ft	16 ft	20 ft	24 ft	28 ft	32 ft
4 ft	4 in.	4 in.	4 in.	5 in.	5 in.	6 in.	6 in.	7 in.
6 ft	4 in.	4 in.	4 in.	5 in.	6 in.	6 in.	6 in.	7 in.
8 ft	4 in.	5 in.	5 in.	6 in.	6 in.	7 in.	7 in.	8 in.
10 ft	5 in.	5 in.	6 in.	6 in.	7 in.	7 in.	8 in.	8 in.

<sup>1</sup>This table represents a relationship between overall flat panel dimensions and thickness below which suggested bowing and warping tolerances should be reviewed with precaster and possibly increased. For ribbed panels, the equivalent thickness should be the overall thickness of such ribs if continuous from one end of the panel to the other. Flat panel thickness governs if ribs are not continuous.

Note: 1 ft = 0.3048 m; 1 in. = 25.4 mm

**Table 1** Guidelines for Panel Thickness for Overall Panel Stiffness Consistent with Suggested Normal Panel Bowing and Warping Tolerances.<sup>1</sup>

Bowing and warping tolerances are of interest primarily at the time the panel is erected. They have an important effect on the edge match-up during erection and on the visual appearance of the erected panels, both individually and when viewed together. The requirements for bowing and warping of panels may be overridden by erection tolerances for panels as installed with reference to joint widths and jog in alignment.

**Table 1** shows the relationship between overall flat panel dimensions and thickness. Panels with thicknesses less than those shown in Table 1 should not be automatically subjected to the standard tolerances for bowing and warping. Note that the thickness values in this table should not be considered as limiting values, but rather as an indication that more detailed consideration of the possible magnitude of warping and bowing is warranted. The major criteria for maintaining or relaxing bowing and warping tolerances will be the appearance requirements, the required type of connections (as well as the number and location of tieback connection points), and the advice of the local precaster regarding overall economic and construction feasibility.

Note: Care must be taken to prevent possible cracking resulting from overstressing the panel in pushing and pulling a bowed panel into tolerance using intermediate tiebacks. To reduce the possibility of panel warpage or bowing, consideration should be given to the panel length, shape, and connection locations. The longer the panel, the more difficult it is to control planeness of the panel.

Panels that are manufactured using large-aggregate concrete (above  $\frac{3}{4}$  in. [19 mm] aggregate) or units that are fabricated from nonhomogeneous materials (such as two significantly different concrete mixtures, natural stone or clay product veneers, insulating mediums, and the like) also require more careful consideration of all aspects of fabrication, storage, and handling with regard to bowing and warping.

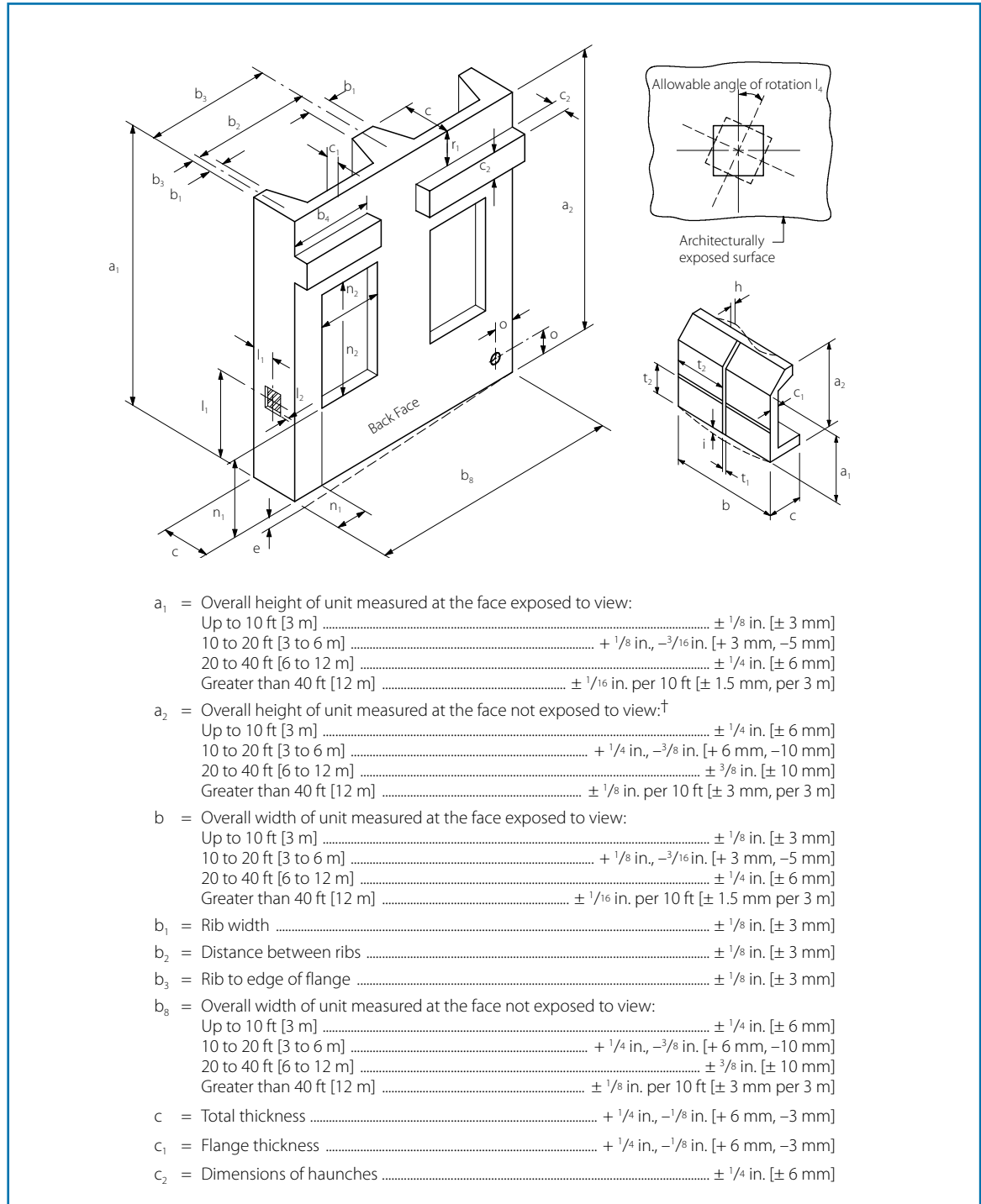

**Figure 1** Architectural Wall Panels.

e	=	Variation <sup>‡</sup> from square or designated skew	.....	± 1/8 in. per 6 ft, ± 1/2 in. max. [± 3 mm per 2 m, ± 13 mm max.]
h	=	Location smoothness, unconcealed surfaces	.....	± 1/4 in. per 10 ft, [± 6 mm per 3 m]
i	=	Bowing	.....	± Length/360, to maximum of 1 in. [25 mm]
j	=	Warp (from adjacent corner)	.....	1/16 in. per ft [1.5 m per 300 mm]
l <sub>1</sub>	=	Location of weld plates	.....	± 1 in. [± 25 mm]
l <sub>2</sub>	=	Tipping and flushness of plates	.....	± 1/4 in. [± 6 mm]
l <sub>4</sub>	=	Allowable rotation of plate, channel insert, electrical box	.....	2 degrees 1/4 in. [6 mm] maximum measured at perimeter of insert
m <sub>2</sub>	=	Haunch bearing surface tipping and flushness of bearing plates	.....	± 1/8 in. [± 3 mm]
m <sub>3</sub>	=	Difference in relative position of adjacent haunch bearing surfaces from specified relative position	.....	± 1/4 in. [± 6 mm]
n <sub>1</sub>	=	Location of opening within panel	.....	± 1/4 in. [± 6 mm]
n <sub>2</sub>	=	Length and width of blockouts and openings within one unit	.....	± 1/4 in. [± 6 mm]
n <sub>3</sub>	=	Location and dimensions of blockouts hidden from view and used for HVAC and utility penetrations	.....	± 3/4 in. [± 19 mm]
o	=	Position of sleeve	.....	± 1/2 in. [± 13 mm]
p	=	Position of insert	.....	± 1/2 in. [± 13 mm]
q	=	Position of handling devices	.....	± 3 in. [± 75 mm]
r <sub>1</sub>	=	Location of bearing surface from end of member	.....	± 1/4 in. [± 6 mm]
s <sub>1</sub>	=	Reinforcing steel and welded wire reinforcement: Where position has structural implications or affects concrete cover	.....	± 1/4 in. [± 6 mm]
		Otherwise	.....	± 1/2 in. [± 13 mm]
s <sub>3</sub>	=	Reinforcing steel extending out of member	.....	± 1/2 in. [± 13 mm]
s <sub>4</sub>	=	Location of strand: Perpendicular to panel	.....	± 1/4 in. [± 6 mm]
		Parallel to panel	.....	± 1 in. [± 25 mm]
t <sub>1</sub>	=	Dimensions of architectural features and rustications	.....	± 1/8 in. [± 3 mm]
t <sub>2</sub>	=	Location of rustication joints	.....	± 1/8 in. [± 3 mm]
w <sub>1</sub>	=	Location of flashing reglets	.....	± 1/4 in. [± 6 mm]
w <sub>2</sub>	=	Location of flashing reglets at edge of panel	.....	± 1/8 in. [± 3 mm]
w <sub>3</sub>	=	Size of reglets for glazing gaskets	.....	± 1/8 in. [± 3 mm]
z	=	Electrical outlets, hose bibs, etc.	.....	± 1/2 in. [± 13 mm]

Tolerances below are for smooth-finished stone veneer-faced precast concrete panels.

1. Variations in cross-sectional dimensions: For thickness of walls from dimensions indicated.....  
..... 1/4 in. (6 mm).

2. Variation in joint width: 1/8 in. in 36 in. (3 mm in 900 mm) or a quarter of nominal joint width,  
whichever is less.

3. Variation in plane between adjacent stone units (lipping): 1/16 in. (1.5 mm) difference between  
planes of adjacent units.

\*Units shall be manufactured so that the face of each unit which is exposed to view after erection complies with the following dimensional requirements.

†Unless joint width and fit-up requirements demand more stringent tolerance.

‡Applies to both panel and to major openings in panel. Tolerances apply to the difference of the two diagonal measurements.

Figure 1 Architectural Wall Panels. (cont.)

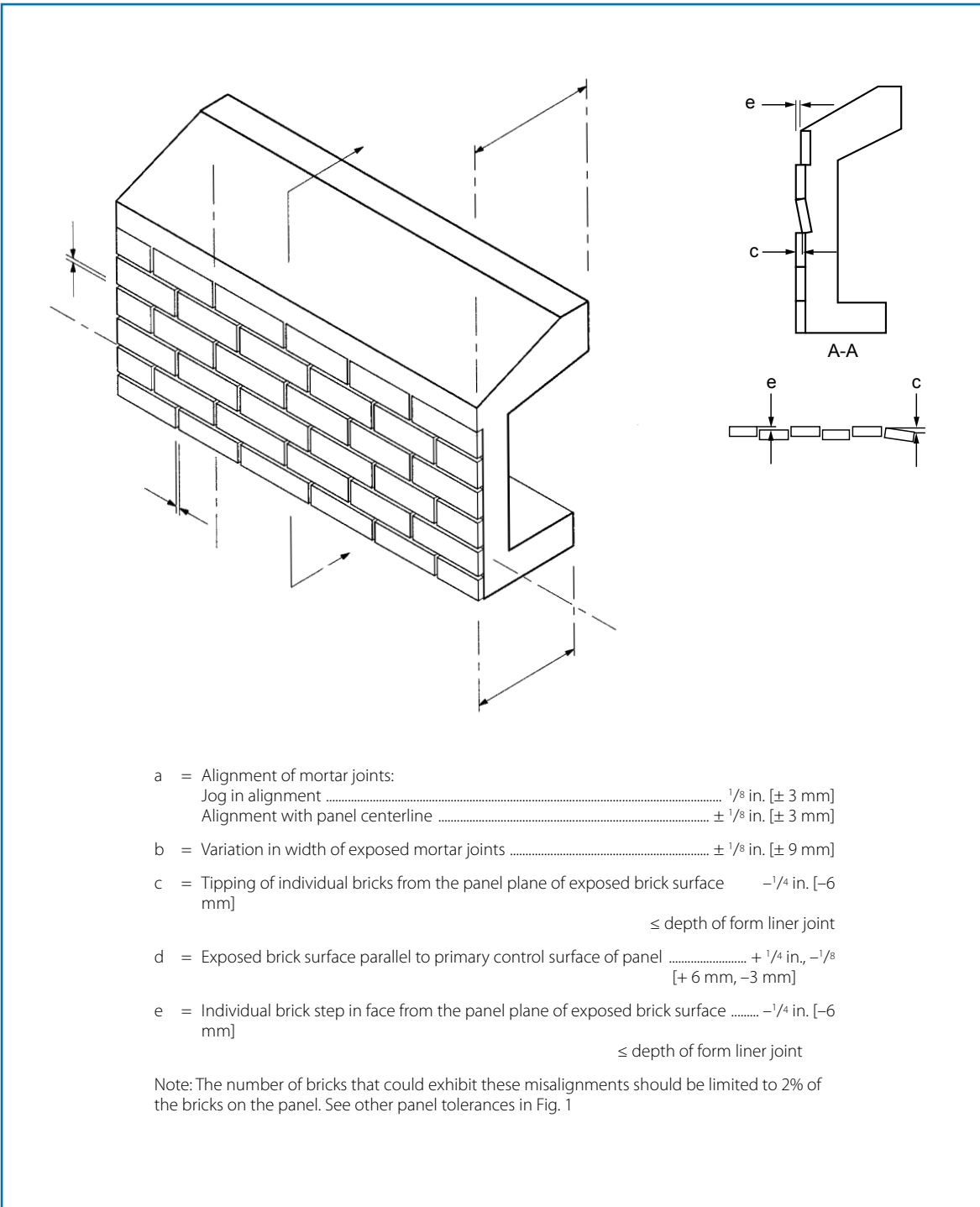

Figure 2 Brick faced architectural elements.



Surface out-of-planeness is defined as a local smoothness variation rather than a bowing of the entire panel shape. The tolerance for this type of variation is usually expressed in fractions of 1 in. per 10 ft (25mm per 3 m).

Dimensional tolerance requirements for architectural precast concrete elements are given in **Figures 1 and 2**. It must be emphasized that these are guidelines only and that each project must be considered individually to ensure that the stated tolerances are applicable.

Groups of inserts or cast-in items that must be located in close tolerance to each other should not be separated into two different panels by a joint.

**Erection Tolerances** - Erection tolerances control the position of the individual precast concrete members as they are located and placed in the assembled structure. They normally involve the general contractor and various subcontractors, such as the precast concrete erector.

Erection tolerances are provided to help achieve uniform joint widths, level floor elevations, and planar wall conditions. Erection tolerances should be determined on the basis of individual unit design, shape, thickness, composition of materials, and overall scale of the unit in relation to the building. The specified erection tolerances may affect the work of several different building trades and must be consistent with the tolerances specified for those trades. If the final erection tolerances are different from those given in this publication, the tolerances should be stated in contract documents and noted on the project precast erection drawings.

The erector is responsible for erecting the members within the specified tolerances and completing the connections in the manner detailed. Appropriate surveying and layout procedures should be followed to ensure accurate application of tolerances. When a unit cannot be erected within the specified tolerances, the erector should notify the precaster and GC/CM to check the structural adequacy of the installation and determine if the connection design should be modified. No unit should be left in an unsafe condition. Any adjustments affecting structural performance, other than adjustments within the prescribed tolerances, should be made only after documented approval by the precast concrete design engineer and engineer of record (if required).

The primary control surfaces or features on the precast concrete members are erected to be in conformance with the established erection and interfacing tolerances (**Fig. 3**). A primary control surface is a surface on a precast element, the dimensional location of which is specifically set and controlled in the erection process. Clearances are generally allowed to vary so that the primary control surface can be set within tolerance. It is important to recognize product tolerances are not additive to the primary surface erection tolerances.

Secondary control surfaces that are positioned from the primary control surfaces by the product tolerances are usually not directly positioned during the erection process, but are controlled by the product tolerances. Thus, if the primary control surfaces are within erection and

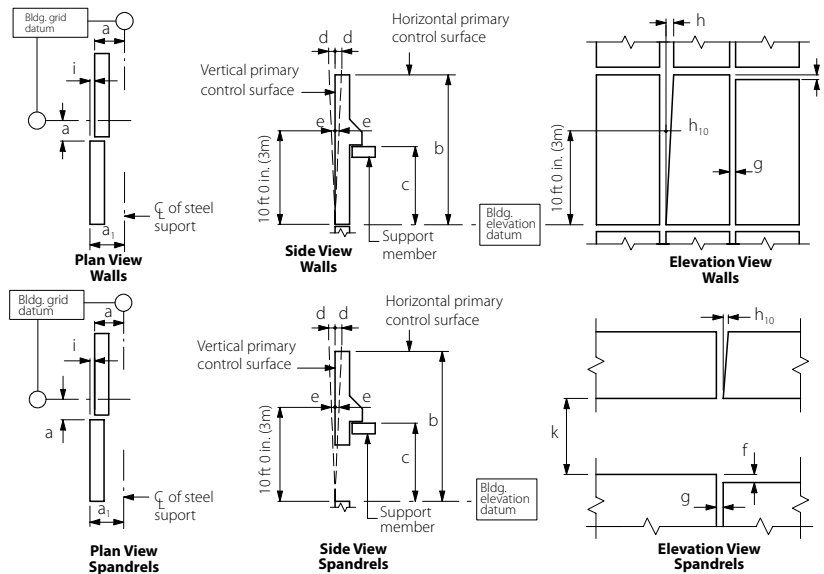

The primary control surfaces are usually as shown, although this needs to be confirmed on a job-by-job basis.

- a = Plan location from building grid datum\* .....  $\pm 1/2$  in. [ $\pm 13$  mm]
- a<sub>1</sub> = Plan location from centerline of steel support<sup>†</sup> .....  $\pm 1/2$  in. [ $\pm 13$  mm]
- b = Top elevation from nominal top elevation:
  - Exposed individual panel .....  $\pm 1/4$  in. [ $\pm 6$  mm]
  - Nonexposed individual panel .....  $\pm 1/2$  in. [ $\pm 13$  mm]
- c = Support haunch elevation from nominal elevation:
  - Maximum low .....  $1/2$  in. [13 mm]
  - Maximum high .....  $1/4$  in. [6 mm]
- d = Maximum plumb variation over height of structure  
or 100 ft [30 m] whichever is less\* ..... 1 in. [25 mm]
- e = Plumb in any 10 ft [3 m] of element height .....  $1/4$  in. [6 mm]
- f = Maximum jog in alignment of matching edges:
  - Exposed relative to adjacent panel .....  $1/4$  in. [6 mm]
  - Nonexposed relative to adjacent panel .....  $1/2$  in. [13 mm]
- g = Joint width (governs over joint taper) .....  $\pm 1/4$  in. [ $\pm 6$  mm]
- h = Joint taper maximum .....  $3/8$  in. [10 mm]
- h<sub>10</sub> = Joint taper over 10 ft [3 m] length .....  $1/4$  in. [6 mm]
- i = Maximum jog in alignment of matching faces .....  $1/4$  in. [6 mm]
- j = Differential bowing or camber as erected between  
adjacent members of the same design .....  $1/4$  in. [6 mm]
- k = Opening height between spandrels .....  $\pm 1/4$  in. [ $\pm 6$  mm]

\*For precast concrete buildings in excess of 100 ft [30 m] tall, tolerances "a" and "d" can increase at the rate of  $1/8$  in. [3 mm] per story to a maximum of 2 in. [50 mm].

<sup>†</sup>For precast concrete elements erected on a steel frame, this tolerance takes precedence over tolerances on dimension "a".

**Figure 3** Architectural walls/spandrels erection tolerances.

interfacing tolerances, and the secondary surfaces are within product tolerances, the member should be considered erected within tolerance. The result is that the tolerance limit for secondary surfaces may be the sum of the product and erection tolerances. Product tolerances, in general, must not exceed erection tolerances.

Because erection and product tolerances for some secondary control surfaces of a precast concrete member may be directly additive, the erection drawings should clearly define the primary erection control surfaces. If both primary and secondary control surfaces are critical, provisions for adjustment should be included. The accumulated tolerance limits may be required to be accommodated in the interface clearance. This may occur with window openings between two spandrels when the critical elevation, top or bottom and as indicated on the erection drawings, must be maintained. If more than one critical line is indicated, the erector should balance any deviations between the two edges. Surface and feature control requirements should be clearly outlined in the plans and specifications.

During panel installation, priority is generally given to aligning the exterior face of the units to meet aesthetic requirements. This may result in the interior face of units being out-of-plane.

Erection tolerances are largely determined by the actual alignment and dimensional accuracy of the building foundation and frame in those circumstances where the building frame is constructed from some material other than precast concrete. The general contractor is responsible for the plumbness, levelness, and alignment of the foundation and non-precast concrete structural frame, including the location of all bearing surfaces and anchorage points for precast concrete products.

The architect/engineer should clearly define in the specifications the maximum tolerances permitted in the foundation and building frame alignment, then should specify that the general contractor check frequently to verify these tolerances are being held. In addition, the architect/engineer should ensure that the details in the contract documents allow for the specified tolerances. To accommodate any misalignment of the building frame, connections should provide for vertical, in-plane lateral and out-of-plane lateral adjustments of at least 1 in. (25 mm).

If the precast concrete units are to be installed reasonably “plumb, level, square, and true,” the actual location of all surfaces affecting their alignment, including the levels of floor slabs and beams, the vertical alignment of floor slab edges, and the plumbness of columns or walls, must be known before erection begins. The general contractor is expected to, and should be required to, establish (and maintain at convenient locations) control points, benchmarks, and lines in areas that remain undisturbed until the completion and acceptance of the project.

Tolerances for the building frame must be adequate to prevent interferences that may cause difficulty with panel installation. Beam elevations and column locations should be controlled within the applicable material tolerances with the appropriate clearance between the precast

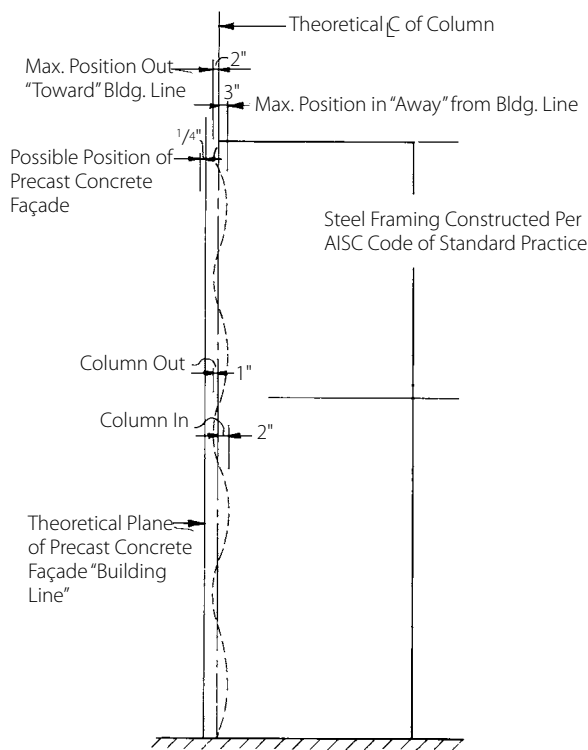

**Figure 4** Clearance example. Note: 1 in. = 25.4 mm.

concrete and support elements.

The location of hardware items cast into or fastened to the structure by the general contractor, steel fabricator, or other trades, should be located  $\pm 1$  in. ( $\pm 25$  mm) in all directions (vertical and horizontal) from the specified location, plus a slope deviation of no more than  $\pm 1/4$  in. ( $\pm 6$  mm) in 12 in. (300 mm) for critical bearing surfaces.

In the determination of erection tolerances, attention should also be given to possible deflection and/ or rotation of structural members supporting precast concrete. This is particularly important when bearing on flexible or cantilevered structural members. Consideration by the engineer of record should be given to both initial and to long-term deflection caused by camber and creep of the supporting structural members.

Structural steel framing tolerances should be specified to conform with the American Institute of Steel Construction (AISC) Code of Standard Practice for Steel Buildings and Bridges, 2010, (see section 16.3). Particular attention is directed to the "Commentary" included in this code, which provides a detailed explanation of the specified erection tolerances.

Mill, fabrication, and erection tolerances combined result in the final dimensional accuracy of the structural steel frame.

Precast concrete tolerances should follow those for the steel frame, because the allowable tolerances for steel frame structures make it impractical to maintain precast concrete panels in a true vertical plane in tall structures. Based on the allowable steel frame tolerances, it would be necessary to provide for a 3 in. (75 mm) adjustment in connections up to the 20th story plus a 2 in. (50 mm) clearance between the back of the precast concrete member and steel frame, **Figure 4**. Above the 20th story, the façade may be maintained within  $1/16$  in. (1.6 mm) per story with a maximum total deviation of 1 in. (25 mm) from a true vertical plane, if connections that provide for 3 in. (75 mm) of adjustment are used. Connections that permit adjustments of +2 in. (+50 mm) to -3 in. (-75 mm) (5 in. [125 mm] total) will be necessary in cases where it is desired to construct the façade to a true vertical plane above the 20th story. These adjustments in connections are not economically feasible.

Anchor Rod Diameter, in. (mm)	Hole Diameter, in. (mm)	Position Tolerance, in. (mm)
3/4 (19)	1 <sup>5</sup> / <sub>16</sub> (33)	±1/4 (±6)
7/8 (22)	1 <sup>9</sup> / <sub>16</sub> (40)	±1/4 (±6)
1 (25)	1 <sup>13</sup> / <sub>16</sub> (46)	±3/8 (±10)
1 <sup>1</sup> / <sub>4</sub> (32)	2 <sup>1</sup> / <sub>16</sub> (52)	±3/8 (±10)
1 <sup>1</sup> / <sub>2</sub> (38)	2 <sup>5</sup> / <sub>16</sub> (59)	±3/8 (±10)
1 <sup>3</sup> / <sub>4</sub> (44)	2 <sup>3</sup> / <sub>4</sub> (70)	±1/2 (±13)
2 (50)	3 <sup>1</sup> / <sub>4</sub> (82)	±1/2 (±13)
2 <sup>1</sup> / <sub>2</sub> (63)	3 <sup>3</sup> / <sub>4</sub> (95)	±1/2 (±13)

**Table 2** Anchor rod hole diameter and position tolerance.

A solution that has proven both practical and economical is to specify the more stringent AISC elevator-column erection tolerances for steel columns in the building façade that will receive the precast concrete panels. This type of solution should be agreed to as part of the design and specification process, or at least prior to finalization of the fabrication erection process.

Cast-in-place concrete frame tolerances are given in ACI 117, *Specification for Tolerances for Concrete Construction and Materials*, unless otherwise stated in the contract documents. ACI tolerances are ± 1 in. up to 83 ft. and linearly varies to ±6 in. at 500 ft. Clearance to cast-in-place frame of 1-1/2 to 2 in. (38 to 50 mm) must also be considered. These tolerances can make precast connections uneconomical. Also, greater variations in height between floors are more prevalent in cast-in-place concrete structures than in other structural frames. This may affect the location or mating of the inserts in the precast concrete units with the cast-in connection devices. Tolerances for cast-in-place concrete structures may have to be increased further to reflect the complexity of the structure. As a result, it is recommended that precast concrete walls should follow concrete frames in the same manner as for steel frames, if the details allow it and appearance is not affected.

The following anchor bolt tolerances, in addition to ACI 117 and AISC requirements, should be specified for cast-in-place concrete to which precast concrete units are to be connected:

- a. Anchor bolt projection: - 1/4 in., + 1/2 in. (-6 mm, + 13 mm).
- b. Plumbness of anchor bolt projection: ± 1/16 in./ft (± 1.6 mm/0.3 m)

To properly mate steel embeds to anchor bolt connections, AISC requirements can be followed. Position tolerances and required hole diameters for various anchor rod sizes are summarized in **Table 2**.

It should be recognized that ACI 117 applies primarily to reinforced concrete buildings, and the AISC Code of Standard Practice applies only to steel building frames. Neither of these standards apply to buildings of composite construction (that is, concrete floor slabs supported by steel columns or concrete-encased structural steel members, fireproofed frames, or steel frames with precast concrete cladding). Obviously, the location of the fireproofing face on the steel, as well as that of the steel member itself, are both critical. Because the alignment of composite members, fireproofing, and masonry work are not controlled by referencing these standards, the architect/engineer should require that the location of all such materials contiguous to the precast concrete units be controlled within tolerances that are no less stringent than those specified in ACI 117. Should there be some doubt as to what these tolerances should be, the precast concrete manufacturer or erector should be consulted for advice.

There is less potential for erection tolerance controversy in structures consisting entirely of precast concrete units than for structures that are combinations of precast and cast-in-place concrete or steel. A total precast concrete structure is erected by one entity with single source responsibility eliminating interfacing with other structural systems. Where precast concrete units connect to site work, such as at footings or foundation walls, larger erection tolerances are particularly necessary but the elevation of haunches or corbels needs to be controlled to obtain level floors.

The erection tolerances of architectural precast concrete are given in **Figure 3**. After precast concrete erection and before other trades interface any materials with the precast concrete members, it should be verified that the precast concrete elements are erected within the specified tolerances.

Because a panel base connection often allows some positioning flexibility, it is often more important to control dimensions from haunch to haunch in walls or multistory columns rather than to maintain tight control of actual haunch location dimensions from the end of the member.

If reasonable tolerances and adjustments have been designed into the construction details, more precise installation and general improvement in appearance are achieved, and the erector should be able to:

1. Avoid joint irregularities, such as tapered joints (panel edges not parallel), jogs at intersections, and non-uniform joint widths.
2. Maintain proper opening dimensions.
3. Properly execute all fastening connections.
4. Align the vertical faces of the units to avoid out-of-plane offsets.
5. Adjust for the accumulation of tolerances.

The precast concrete erector should perform a survey of the building as constructed and lay out joint center-lines spaced along an elevation prior to actual product installations and center the units between them. This will keep the differential variation in joint width to a minimum, as well as identifying problems caused by building frame columns or beams being out of dimension or alignment. Horizontal and vertical joints should be aligned and uniform joint widths should be maintained as erection progresses.

Variations from true length or width dimensions of the overall structure are normally accommodated in the joints or, where this is not feasible or desirable, at the corner panels, in expansion joints, or in joints adjacent to other wall materials. A liberal joint width should be allowed if variations in overall building dimensions are to be absorbed in the joints. This may be coupled with a closer tolerance for variations from one joint to the next for uniformity of appearance purposes. The individual joint width tolerance should relate to the number of joints over a given building dimension. For example, to accommodate reasonable variations in actual site dimensions, a  $\frac{3}{4}$  in. (19 mm) joint may be specified with a tolerance of  $\pm \frac{1}{4}$  in. ( $\pm 6$  mm) but with only a  $\frac{3}{16}$  in. (5 mm) differential variation allowed between joint widths on any one floor or between adjacent floors.

In a situation where a joint must match an architectural feature (such as a false joint), a large variation from the theoretical joint width may not be acceptable and tolerance for building lengths may need to be accommodated at the corner panels. A similar condition often occurs where precast concrete is interspersed with glass or curtain wall elements, as in precast concrete mullion projects.

**Clearance** - Clearance is the space provided between the structure and the back surface of precast concrete members. It is one of the most important factors to consider in erection because of its impact on the final appearance of the structure. The clearance space should provide a buffer area where frame, erection, and product tolerance variations can be absorbed. Clearances should be reviewed during the design stages of the project to ensure they are appropriate from both erection and aesthetic points of view.

With reasonable tolerances for the building frame established, it is equally important that the designer provide adequate clearances, for example, between the theoretical face of the structure and the back face of a precast concrete panel in detailing the panel and its relationship to the building structure. If clearances are realistically assessed, they will enable the erector to complete the final assembly without field-altering the physical dimensions of the precast concrete units. Adjacent materials may include products such as glass or subframes that are installed after the precast concrete panels are in place. If sufficient space is not provided, alignment of the wall as specified will likely necessitate delays and extra costs and alignment may be impossible.

Designing clearances should consider not only the dimensional tolerance of the precast con-

crete members, but also the dimensional accuracy of the support system (building frame).

The type of member is partially accounted for when product tolerances are considered. There are additional factors that should also be considered. An exposed to-view member requiring small erection tolerances requires more clearance for adjustment than a non-exposed member with a more liberal erection tolerance. Similarly, a corner member should have a large enough clearance so it can be adjusted to line up with both of the adjacent panels.

The size and weight of the member are other considerations in determining erection clearances. Large members are more difficult to handle than smaller ones; a large member being erected by a crane requires more clearance than small member that can be hand-erected or adjusted.

Clearance design should consider member deflection, rotation, and movements caused by temperature expansion and contraction, creep, and shrinkage. Clearance between a vertical member and a horizontal member should allow for some movement in the horizontal member to prevent the vertical member from being pushed or pulled out of its original alignment.

Consideration should be given to the limits of adjustment permitted by the connection details. All connections should provide maximum adjustability in all directions that is structurally or architecturally feasible. When a 1 in. (25 mm) clearance is needed but a 2 in. (50 mm) clearance creates no structural or architectural difficulty, the 2 in. (50 mm) clearance should be selected. Closer tolerances are required for bolted connections than for most grouted connections. To accommodate any misalignment of the building frame, connections should provide for vertical, in-plane lateral, and out-of-plane lateral adjustments of at least 1-1/2 in. (38 mm). If a connection is attached to a spandrel beam or column that is fireproofed, more clearance will be needed to install fastenings than when the anchors are located on the top surface of beams and the sides of columns. Also, space should be provided to make the connection (sufficient room for welding or adequate space to place a wrench to tighten a bolt).

Nominal clearance dimensions shown on the erection drawings should be equal to the actual clearance required plus the outward tolerance permitted for the adjacent construction, and should be determined based on the assumption that the construction will be as far out of position in the wrong direction as is allowed. Special attention should be given to complex geometric interfaces. Connections should be designed to accommodate the clearance plus tolerance.

If the clearance provided is too tight, erection may be slow and costly because of fit-up problems and the possibility of rework. A good rule of thumb is that at least 3/4 in. (19 mm) clearance should be required between precast concrete members, with 1 in. (25 mm) preferred; 1-1/2 in. (38 mm) is the minimum clearance between precast concrete members and cast-in-place concrete, with 2 in. (50 mm) preferred. For steel structures, 1-1/2 in. (38 mm) is the minimum clearance between the back of the precast concrete member and the surface of the fireproofing, with 2 in. preferred. If there is no fireproofing required on the steel, then 1-1/2



in. (38 mm) minimum clearance should be maintained. At least a 1-1/2 to 2 in. (38 to 50 mm) clearance should be specified in tall structures, regardless of the structural framing materials. The minimum clearance between column covers and columns should be 1-1/2 in. (38 mm); 3 in. (75 mm) is preferred because of the possibility of columns being out of plumb or a column dimension causing interference with completion of the connection. If clearances are realistically assessed, they will solve many installation problems.

**Interfacing Tolerances** - Interfacing tolerances and clearances are required for the joining of different building materials in contact with or in close proximity to precast concrete, and to accommodate the relative movements expected between such materials during the life of the building. Typical examples include tolerances for window and door openings; joints, flashing, and reglets; mechanical and electrical equipment; elevators and interior finishes; and walls and partitions.

Fabrication and erection tolerances of other building materials must also be considered in design of the precast concrete units and coordinated to accommodate the other functional elements comprising the total structure. Evaluation of interfacing tolerances should be done during design coordination meetings, preconstruction meetings, and pre-submittal coordination. Unusual requirements or allowances for interfacing should be stated in the contract documents.

When the matching of different building elements is dependent on work executed at the construction site, interface tolerances should be related to erection tolerances. When the execution is independent of site work, tolerances should closely match the normal manufacturing tolerances for the materials to be joined plus an appropriate allowance (clearance) for differential volume changes between materials. For example, window elements have installation details that require certain tolerances on window openings in a precast concrete panel. If the opening is completely contained within one panel, can the required tolerances on the window opening be economically met? If not, is it less expensive to procure special windows or to incur the added cost associated with making the tolerances on the window opening more stringent? Also, openings for aluminum windows should allow clearance for some thermal expansion of the frame.

The following installation tolerances developed by the window wall, and window installers and/or associations along with louver tolerances need to be considered to properly interface with precast concrete panels:

**Aluminum curtain walls (prefabricated)**

Position of components from location shown on the drawings.....  $\pm 1/8$  in. (3mm)

Offset alignment between two identical members end to end..... $1/16$  in. (1.5 mm) max.

Variation from plane..... $1/8$  in. per 12 ft. (3mm per 3600 mm, or  $1/2$  in. (12 mm) max. in any length

Variation in diagonal lengths within any rectangular opening in a curtain wall unit.....  $\frac{1}{8}$  in. (3mm) max.

Variation of mullions from plumb or horizontal in any single run.....  $\pm \frac{1}{8}$  in. in 12 ft (3 mm in 3660 mm) or  $\pm \frac{1}{4}$  in. (6 mm) max.

Out-of-plane offset of horizontal and vertical glazing legs in the same plane .....  $\frac{1}{32}$  in. (0.8mm) max.

### **Storefront systems, window wall, and entrances in multi-story buildings**

Difference in length of diagonals of any rectangular opening.....  $\frac{1}{8}$  in. (3mm) max.

Variation in plumb or level.....  $\pm \frac{1}{8}$  in. in 12 ft (3 mm in 3660 mm), or  $\pm \frac{1}{4}$  in. (6mm) max. in any single run

### **Aluminum windows**

Overall height and width, dimensions 72 in. (1830 mm) and under.....  $\pm \frac{1}{16}$  in. (1.5 mm)

Overall height and width, dimensions between 72 in. (1830 mm) and 144 in (3660 mm) .....  $\pm \frac{1}{8}$  in. (3 mm)

Overall height and width, dimensions over 144 in. (3660 mm).....  $\pm \frac{3}{16}$  in. (4.5 mm)

### **Steel windows**

Overall height and width of window unit.....  $\pm \frac{1}{16}$  in. (1.6 mm)

### **Hollow metal glazed openings**

Overall height and width of frame opening.....  $+\frac{1}{16}$  in. (1.6 mm),  $-\frac{1}{32}$  in. (0.8 mm)

Frame depth: .....  $\pm \frac{1}{16}$  in. (1.6 mm)

Frame face width: .....  $\pm \frac{1}{32}$  in. (0.8 mm)

### **Louvers**

Opening size  $\frac{1}{2}$  in. (13 mm) larger than louver assembly,  $\frac{1}{4}$  in. (6 mm) at each side.

It is important to note that interfacing tolerances may be system dependent. For example, windows of one type may have a different interface tolerance than windows of another type. If material or component substitutions are made after the initial design is complete, the responsibility for ensuring that the interface tolerances are compatible with adjacent building materials passes to the party initiating the substitutions.

Adequate interface/erection tolerances are required for window openings, doors, or louvers common to two or more panels. The cost of erecting the panels to achieve required

window interface tolerances must also be considered. A similar condition often occurs where precast concrete is interspersed with glass or metal curtain wall elements, as in many precast concrete spandrel or mullion projects.

Product tolerances, erection tolerances, and interface tolerances together determine the dimensions of the completed structure. Which tolerance takes precedence is a question of economics, which should be addressed by considering fabrication, erection, and interfacing cost implications.

Special tolerances or construction procedures require early decisions based on overall project economics. Once these decisions have been made, they should be reflected in the project plans and specifications. All special tolerance requirements or allowances for interface, special details, and special procedures should be clearly spelled out in the specifications. The plans and specifications then define the established tolerance priority for the project. 



# designer's notebook



Precast/Prestressed Concrete Institute

200 West Adams Street | Suite 2100 | Chicago, IL 60606-5230  
Phone: 312-786-0300 | Fax: 312-621-1114 | [www.pci.org](http://www.pci.org)