



Precast/Prestressed Concrete Institute

Stone Veneer-Faced Precast

PCI's Architectural Precast Concrete Services Committee highlights how precast can achieve the same goals as stone façades



designer's notebook

Stone Veneer-Faced Precast Offers Cost Efficiencies—Article VIII



State Office Tower II, in Columbus, Ohio, has 3 cm of granite on 5- and 7-inch-thick precast concrete backup. (Architect Bohm-NBBJ)

PCI's Architectural Precast Concrete Services Committee highlights how precast can achieve the same goals as stone façades

Natural stone has been used widely in building construction for centuries due to its strength, durability, aesthetic effect, availability and inherent low costs for maintenance. In the 1960's, the practice of facing skeleton-frame structures with large prefabricated concrete components to decrease construction time and reduce costs resulted in a combination of the rich beauty of natural stone veneer and the strength, versatility and economy of precast concrete.

Stone veneer-faced precast concrete panels offer many benefits. These include:

1. Veneer stock can be used in thinner sections because anchoring points may be placed closer together.
2. Multiplane units such as column covers, spandrels with integral soffit and sill sections, deep reveal window frames, inside and outside corners, projections and setbacks, and parapet sections are more economically assembled as veneer units on precast concrete panels (**Fig. 1**).
3. Precast concrete backup systems permit faster enclosure, allowing earlier work by other trades and subsequent earlier occupancy, because each of the larger panels incorporate a number of veneer pieces.
4. Veneered precast concrete panels can be used to span column-to-column, thereby reducing floor-edge loading and eliminating elaborate temporary scaffolding.

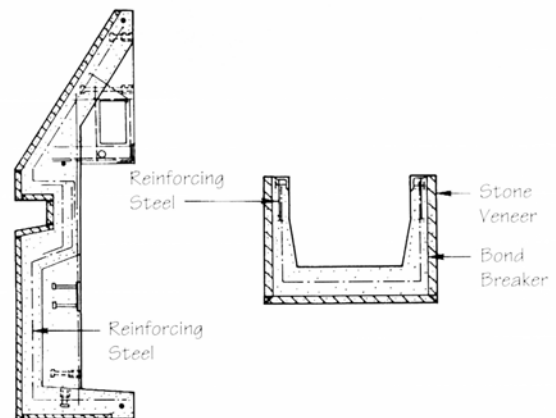

Figure 1 Typical spandrel and column cover panels.

General Considerations

The purchaser of the stone should appoint a qualified individual to be responsible for coordination. This person should oversee delivery and scheduling responsibility and should ensure acceptable color uniformity. Color control or blending of the stone veneer should take place at the stone fabricator's plant, where ranges of color and shade, finishes and markings such as veining, seams and intrusions are viewed most easily. Acceptable stone color should be judged for an entire building elevation rather than as individual panels. The responsibility for stone coordination should be written into the specifications so its cost can be bid. The owner, architect and precaster should visit the stone fabricator's plant to view the stone veneer and establish criteria and methods for color range blending on the project.

Separate subcontracts and advance awards often occur in projects with stone-veneered panels. While these procedures may affect normal submission routines, it is not intended that responsibilities for accuracy should be transferred or reassigned. The precaster is responsible for precast concrete details and dimensions, while the stone-veneer fabricator is responsible for stone details, dimensions and drilling of anchor holes.

The production of stone veneer panels requires adequate lead time in order to avoid construction delays. Therefore, it is important that approvals for shop drawings are obtained expeditiously. Furthermore, it is recommended that the designer allow the submission of shop drawings in predetermined stages so manufacturing can begin as soon as possible and ensure there is a steady and timely flow of approved information to allow uninterrupted fabrication.

The precast concrete producer must provide the stone quantity and sequence requirements to meet the erection sequences. The precaster and stone fabricator should coordinate packaging requirements to minimize handling and breakage. Extra stone (approximately 2 to 5 percent) should be supplied to allow immediate replacement of damaged stone pieces, particularly if the stone is not supplied from a domestic source.

Because of the difference in material properties between natural stone and concrete, veneered panels are more susceptible to bowing than all-concrete units. However, panel manufacturers have developed design and production procedures to minimize bowing.

The panel manufacturer and designer should consider the following in design and production in order to minimize or eliminate panel bowing:



Two 18-story towers for GSA Federal Building, Oakland, Calif. are clad with 1-³/₄ inch beige and white-hued limestone. (Architect Kaplan McLaughlin Diaz)

1. The temperature differential (exterior to interior).
2. Coefficients of expansion of the materials.
3. Ratio of cross-sectional areas of the materials and their moduli of elasticity.
4. Amount, location and type of reinforcement in the concrete panel.
5. The use of prestressing.
6. Type and location of connections to the structure.
7. Rigidity of connection between stone veneer and concrete backup (too rigid may cause problems).
8. Shrinkage of the concrete.

Minimum thickness of backup concrete on flat panels that will control bowing or warping is usually 5 to 6 inches, but 4 inches has been used where the panel is small, or it has adequate rigidity obtained through panels shape or thickness of natural stone. See

Figure 2 for mold considerations. Cover depth of reinforcement must be a minimum of $\frac{3}{4}$ inch at the veneer surface. Non-corrosive spacers such as plastic should maintain this cover.

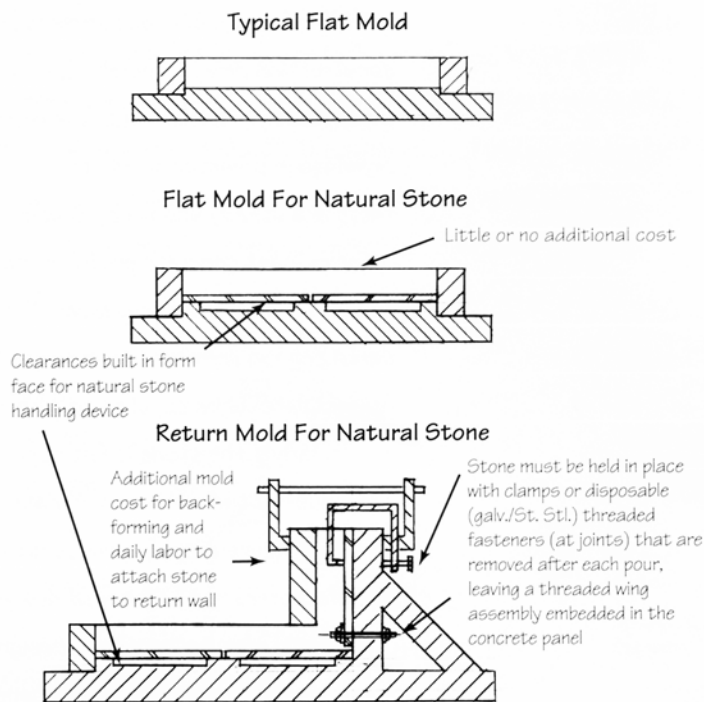

Figure 2 Molds.

Stone Strength

The strength of natural stone depends on several factors: the size, rift and cleavage of crystals, the degree of cohesion, the interlocking geometry of crystals, the nature of natural cementing materials present and the type of crystal. The stone's properties will vary with the locality from which it is quarried. Therefore, it is important that current testing is performed for stone quarried for a specific project.

Sedimentary and metamorphic rocks, such as limestone and marble, will exhibit different strengths when measured parallel and perpendicular to their origi-

nal bedding planes. Igneous rocks, such as granite, may or may not exhibit relatively uniform strength characteristics on the various planes. In addition, the surface finish, freezing and thawing, and large temperature fluctuations will affect the strength and in turn influence the anchorage system.

Information on the durability of the specified stone should be obtained through current testing in conjunction with observations of existing installations of that particular stone. This information should include such factors as tendency to warp, reaction to weathering forces, resistance to chemical pollutants, resistance to chemical reaction from adjacent materials and reduction in strength from the effects of weathering or wetting and drying.

Prior to awarding the precast concrete contract, tests should be performed to determine the physical properties of the stone being considered. The testing should be done on stone with the same finish and thickness to be used on the structure. Flexural tests (ASTM C880) should be used to evaluate the physical properties and obtain design values. Absorption testing (ASTM C97) helps evaluate freeze-thaw durability. These properties, along with properties of the anchor system, should be used to ensure adequate strength of the panel to resist loads during handling, transportation, erection and in-service conditions.

Stone Sizes

Stone veneers used for precast facing are usually thinner than those used for conventionally set stone, with the maximum size generally determined by the stone strength. **Table 1** summarizes typical dimensions. Veneers thinner than those listed can result in anchors being reflected on the exposed surface, excessive breakage or permeability problems.

The length and width of veneer materials should be sized to a tolerance of $+0 - 1/8$ inch, since a plus tolerance can present problems on precast concrete panels. This tolerance becomes important when trying to line up the false joints on one panel with those on the panel above or below, particularly when there are a large number of pieces of stone on each panel. Tolerance allowance for out-of-square is $\pm 1/16$ inch difference in length of the two diagonal measurements.

	Minimum recommended thickness (in.)	Length range (ft.)	Width range (ft.)	Maximum area (ft ²)
Marble	1.25	3-5	2-5	25
Travertine*	1.25	2-5	1-4	16
Granite	1.25	3-7	1-5	30
Limestone	2.00	4-5	2-4	15

* Surface voids filled front and back

Table 1 Dimensional parameters of various stone materials

Flatness tolerances for finished surfaces depend on the type of finish. For example, the granite industry's flatness tolerances vary from $3/64$ inch for a polished surface to $3/16$ inch for flame (thermal) finish when measured with a 4-foot straight edge. Thickness variations are less important, since concrete will provide a uniform back face except at corner butt joints. In such cases, the finished edges should be within $\pm 1/16$ inch of the

specified thickness. However, large thickness variations may lead to the stone being encased with concrete and thus restrict relative movement of the materials. The aesthetic problems that occur with tolerances concern the variation from a flat surface on an exposed face and stone pieces being out of square.

Anchorage of Stone Facing



Southwestern Bell, Dallas, Texas has 3 cm travertine anchored to 7055 precast concrete units. (Architect JPL Architects)

The stone fabricator or precaster appear to have the dominant responsibility for conducting the anchor tests, with the architect or engineer of record occasionally determining the type of anchorage. However, it is preferable for the architect to determine anchor spacing so that common information can be supplied to all bidders (refer to ASTM C1242). Contract documents should define clearly who drills the anchor holes in the stone; type, number and location of anchors; and who supplies the anchors. In most cases, the stone fabricator drills the anchor holes in the stone using a diamond-core bit with a non-pneumatic tool.

It is recommended that the precaster detail all precast units to the point where the fabricator of the veneer is able to incorporate details, sizes and anchor holes for the individual stone pieces.

It also is recommended that there be no bonding between stone veneer and concrete backup in order to minimize bowing, cracking and staining of the veneer. Flexible mechanical anchors should be used to secure the veneer.

Two methods may be used to prevent bond between the veneer and concrete to allow for independent movement: a 6-mil polyethylene sheet or a closed-cell, $\frac{1}{8}$ - to $\frac{1}{4}$ -inch polyethylene foam pad. Using a compressible bondbreaker is preferred because it allows movement of stones with uneven surfaces, either of individual pieces or between stone pieces on a panel.

Preformed anchors, $\frac{1}{8}$ - to $\frac{5}{8}$ -inch in diameter, fabricated from Type 304 stainless steel, are supplied by the stone fabricator or, in some cases, by the precaster depending on the contract document requirements. The number and location of anchors should be determined by a minimum of five shear and tension tests conducted on a single anchor embedded in a stone/precast concrete test sample using ASTM E488 or ASTM C1354 and the anticipated applied loads, both normal and transverse to the panel. Care should be taken in grasping the anchor.

Design of anchorage and size of the stone should be based on specific test values for the actual stone to be installed. Test samples for anchor tests should be a typical panel section of about 1 square foot and approximate as closely as possible actual panel anchoring conditions. A bondbreaker should be placed between stone and concrete during sample manufacture to eliminate any bond between veneer and concrete surface. Depending on the size of the project, it may be desirable to perform shear and tensile tests of the anchors at intervals during the fabrication period.

Four anchors usually are used per stone piece, with a minimum of two recommended. The number of anchors has varied from one per 1½ square foot of stone to one per 6 square feet, with one per 2 to 3 square feet being the most common. Anchors should be 6 to 9 inches from an edge with not more than 24 to 30 inches between anchors depending on the local building code. The shear capacity of the spring clip (hairpin) anchors perpendicular to the anchor legs is greater than when they are parallel, and capacity depends on the strength of the stone. A typical marble veneer anchor detail with a toe-in spring clip (hairpin) anchor is shown in **Figure 3**, while a typical granite veneer anchor detail is shown in **Figure 4**. The toe-out anchor in granite may have as much as 50 percent more tensile capacity than a toe-in anchor, depending on the stone strength.

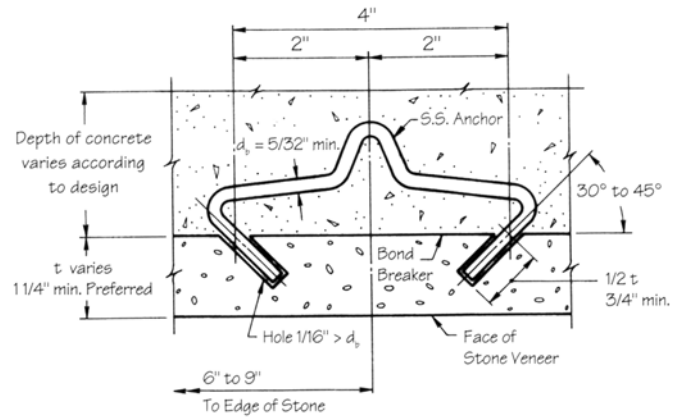

Figure 3 Typical anchor for marble veneer.

Depth of anchor holes should be approximately half the thickness of the veneer (minimum depth of ¾ inch). Minimum concrete cover over the drilled hole should be ¾ inch to avoid spalling during drilling and spotting from absorbed moisture. The hole should be drilled at an angle of 30 to 45 degrees to the plane of the stone. Holes 1/16 inch larger than the anchor are common, as excessive looseness reduces holding power. Anchor holes should be within ± 3/16 inch of the specified hole spacing, particularly for the spring clip anchors.

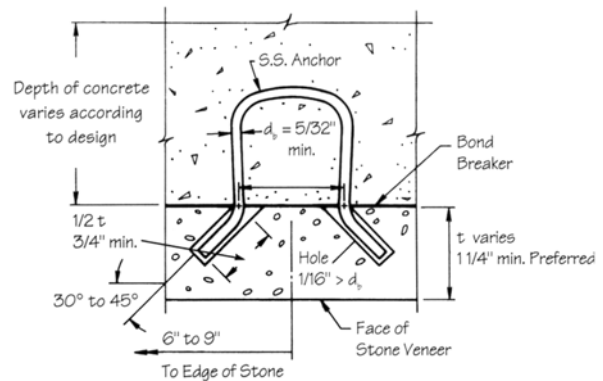

Figure 4 Typical anchor for granite veneer.

Stainless-steel dowels, smooth or threaded, may be installed to a depth of two-thirds of the stone thickness, with a maximum depth of 2 inches at 45- to 60-degree angles to the plane of the stone. The minimum embedment in the concrete backup to develop the required bond length is shown in **Figure 5**. Dowel size varies from 3/16 to 5/8 inch for most stones, except that it varies from 1/4 to 5/8 inch for soft limestone and sandstone and depends on thickness and strength of stone.

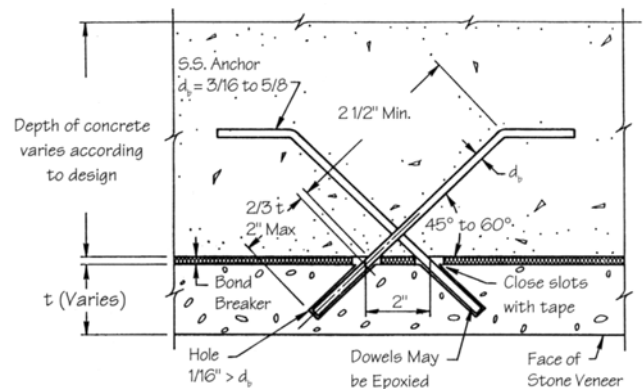

Figure 5 Typical cross anchor dowels for stone veneer.

Limestone traditionally has been bonded and anchored to the concrete, because it has the lowest coefficient of expansion. Limestone also has been used traditionally in thicknesses of 3 to 5 inches, but it is now being used as thin as 1¾ inches. If limestone is to be bonded, use a moisture barrier/bonding agent on the backside of the stone to eliminate the possibility of staining the stone veneer with alkali salts in the concrete. When limestone is 2 inches or thinner,

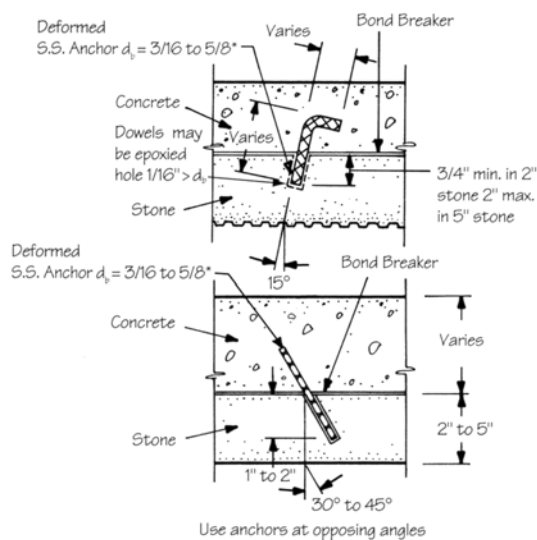

Figure 6 Typical anchors for limestone veneer.



Figure 7 This is an example of a compressible sleeve used to reduce stone anchor rigidity when the anchors are epoxied in the stone.

use a bondbreaker along with mechanical anchors. Dowels and spring-clip anchors can be used to anchor limestone. Typical dowel details for limestone veneers are shown in **Figures 5 and 6**. The dowels in **Figure 6** should be inserted at opposing angles to secure stone facing to the backup concrete.

Some flexibility should be introduced with all anchors by minimizing the anchor's diameter, to allow for the inevitable relative movements that occur with temperature variations and concrete shrinkage. Unaccommodated relative movements can result in excessive stress problems and eventual failure at an anchor location. Depending on the size of the project, consideration may be given to accelerated cyclic temperature tests to determine the effects on the anchors.

Some designers use two-part polyester or epoxy to fill the anchor holes in order to eliminate intrusion of water into the holes and to prevent the possible dark, damp appearance of moisture on the exposed stone surface. The polyester or epoxy increases the shear capacity and rigidity of the anchors. The rigidity may be partially overcome by using 1/2-inch-long compressible

(60 durometer) rubber or elastomeric grommets or sleeves on the anchor at the back surface of the stone as seen in **Figure 7**.

Differential thermal expansion of the stone and unfilled epoxy may cause cracking of the stone veneer. The coefficient of expansion of epoxy and stone should closely match. It may be more desirable to fill the anchor hole with a low modulus polyurethane sealant. The overall effect of either epoxy or sealant materials on the behavior of the entire veneer should be evaluated prior to their use. At best, the long-term service of epoxy is questionable, so any increase in shear value should not be used in calculating long-term anchor capacity.

The stone trade associations and the suppliers of different kinds of building stones recommend safety factors. Because of the expected variation in the physical properties of natural stones and the effects of weathering, recommended safety factors are larger than those used for manufactured building materials, such as steel and concrete. The minimum recommended safety factor, based on the average of the test results, is 4 for anchorage components. If the range of test values exceeds the average by more than ± 20 percent, then the safety factor should be applied to the lower bound value. (See Appendix to ASTM C1242 for a discussion on safety factors.)

Finite-element analysis is a useful technique for evaluating stress in a veneer panel system. This necessitates testing to determine the spring constant values for the panel's material components to model the assembly. Stone veneer should be tested in flexure, (ASTM C1352). The section properties and modulus of elasticity also should be determined. Granite rift (bedding) planes, direction and grain size influence modulus of elasticity. Shear and tensile tests

are required for the anchors. The spring constant of a compressible bond breaker should be determined. For insulation, compressive-spring and shear-spring constants should be determined if no bondbreaker is used.

The bondbreaker between the stone veneer and concrete backup may function as a vapor barrier on the concrete's exterior face, keeping moisture in the veneer or at the interface, unless drainage provisions are provided. After some time, gaps also may develop between the stone veneer and concrete backup at the bond breaker. These gaps could allow moisture penetration due to capillary and gravity action, particularly where the window or roof design allows water to puddle on top of the panel. One solution is to apply a sealant to the top and side edges of the stone/concrete interface after the panels are cast. Care must be taken to ensure that the sealant used is compatible with the sealant to be applied to panel joints after erection of the panels.

Panel Watertightness

The bondbreaker should not be sealed at the bottom of the panel. This ensures any moisture that somehow penetrates the stone veneer can drain freely. In the case of long panels, a sloping gutter is sometimes used not only under the window but also at every horizontal joint.

Veneer Jointing

Joints between veneer pieces on a precast panel are typically a minimum of $\frac{1}{4}$ inch, although they have been specified equal to the joint width between precast elements, usually $\frac{1}{2}$, $\frac{3}{4}$ or 1 inch, depending on the panel size. As actual joint width between precast panels (as erected) depends largely on the accuracy of the main supporting structure, it is not realistic to require matching joint widths between stone pieces and between panels.

Often, an invisible joint is specified, e.g., less than $\frac{3}{16}$ inch, especially on polished veneer. This simply is not possible because the joint must have the width necessary to allow for movements, tolerances, etc.



Precast concrete panels are integrally cast with Arizona Red sandstone on the Roseville Telephone Company in Roseville, Calif. (Architect *Williams & Paddon Architects & Planners, Inc.*)



Architectural precast panels for the new wing of the Joslyn Art Museum, Omaha, Neb., are clad in Georgia marble to match the original stone building constructed in 1931. Labor and material cost were reduced using this system compared to traditional stone cladding systems.

(Architect *Henningson, Durham & Richardson Inc.*)



German limestone is anchored to precast panels on the Terry Sanford Institute of Public Policy at Duke University in Durham, N.C. (Architect *Architectural Resources Cambridge Inc.*)

Also, due to tolerances and natural warping, adjacent panels may not be completely flush at the joint, and shadow lines will appear. Rather than attempting to hide the joint, it should be emphasized by finding an aesthetically pleasing joint pattern with a complementary joint size.

When stone veneer is used as an accent or feature strip on precast concrete panels, a 1/2-inch space is left between the edge of the stone and the precast concrete to allow for differential movements of the materials. This space is then caulked as if it were a conventional joint. Caulking between stones or panels should be an elastomeric, usually urethane, polysulfide or silicone, which won't stain the stone-veneer material. Some grades of silicone sealants are

not recommended by their manufacturers for application on stone, as they may stain light-colored stones. In some projects, caulking between stone pieces on a panel may be installed more economically and satisfactorily at the same time as the caulking between precast elements. On other projects. Consideration may be given to caulking the veneer material at the plant. Plant caulking of stone-to-stone joints is recommended in areas subject to freezing and thawing, if panels will be left in prolonged storage during winter months.



Polished granite feature strips on Shriners Hospital for Children, Sacramento, Calif. (Architect *Odell Associates, Charlotte, N.C.* and Associate Architect: *HDR, Omaha, Neb.*)

Repair

Should minor damage occur to the veneer stone during shipping, handling or erection, field remedial work can be performed successfully. The precaster normally does such repairs, with repair procedures developed in consultation with the stone fabricator (see **Fig. 8**).

Epoxy, stone dust and a coloring agent, if necessary, are used to repair small chips or spalls. These patches can be finished to the

same surface texture as the stone facing. If it is necessary to replace a stone piece, satisfactory techniques have been developed for when the back of the panels is accessible or after the panels have been erected and the back of the panels is inaccessible.

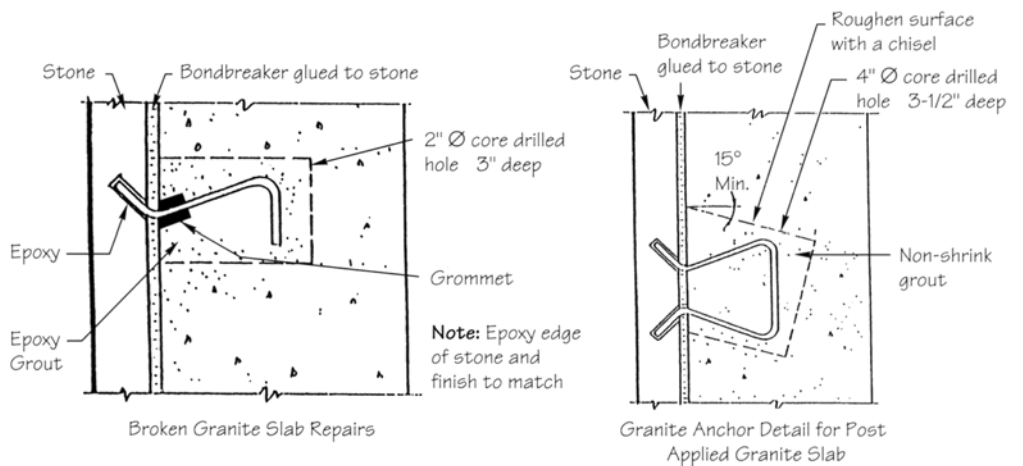

The Beauty of Stone Meets the Ease of Precast

Jim Rothwell, principal with Callison Architecture Inc., explains a cost-effective way to apply stone to buildings in today's construction market

Over the course of designing millions of square feet of buildings, we have dealt with many exterior materials and methods of installation. In recent years, we have found that stone applied to precast is a cost- and schedule-effective solution.

Building with stone is a choice made for a variety of mostly aesthetic reasons—contextual, historical, image, surface variation and durability. However, in today's construction market, building with solid stone is not economical. As an option to solid stone block, architects wanting to achieve the aesthetic or functionality that stone offers can use stone veneer.

There are three primary options for installing stone veneer: on studs, on steel strong back or on precast. All offer a more cost-effective solution than solid stone. Because the backs aren't visible in the final product, the choice of backing for the stone veneer is not an aesthetic one but one of function, economy and schedule.

Stone on Precast Systems

The primary reasons we have chosen to use stone veneer on precast have been based on several factors. These include compatibility with surrounding materials, the structural system or the construction method. If a building is constructed of precast concrete, then it is obvious that you would put the stone on precast backing, too. If it is brick or some other system, the decision to use stone on precast may be based on factors such as labor, close proximity to a precast plant or weather conditions.

For 1700 Seventh Avenue, a 525,000-square-foot Class A office building with ground-level retail in downtown Seattle, we wanted the design to have an understated, timeless quality appropriate to its surroundings. While the façade is primarily precast concrete, the base of the building features a natural, matte granite that is historically appropriate for that part of town. It also is durable and resistant to weather and vandalism.

Of the installation choices—hand set, stone on steel strongback system and stone on precast—we selected stone on precast for two reasons. First, it was the most cost effective. Second, it offered ease of coordination with the other precast components it touches, providing a good method to get a true secondary-seal weather joint, an important consideration with Seattle’s rainy weather.

The stone-on-precast system here gives us a primary and secondary seal—a primary seal at the base of the panel and the secondary seal at the back of the panel. This creates an air chamber be-

tween the two seals that helps drop water out of the building as opposed to pushing it through the building with pressure. In addition, if the stone has porosity, the precast provides another layer of material for water protection.

Another advantage of stone on precast is quality and schedule control. Any components that can be manufactured in a precast plant in a controlled environment, using established quality standards, offer a better chance of maintaining quality. Since it also offers a panelized system, incorporating the stone into the panels eliminates a step.



The Wellpoint Executive Center in Thousand Oaks, Calif., combines natural sandstone veneer-faced panels and precast to create a strong horizontal rhythm that blends into the hilltop.



The precast panels used in Wellpoint's Executive Center were custom-matched in both color and texture to the stone veneer.

Combining Cast and Field-Set Stone

For a retail building under construction in downtown Chicago, we used a combination of stone cast into the precast panels and field-set stone. The building features precast construction with glass curtain wall, with the stone detail supplying richness of texture and color. Working in a climate with freeze-thaw conditions, panels prefabricated with the stone in place solves many of the problems of working in cold weather.

Because of weatherproofing conditions at the base of the building, a cast-in-place foundation was used below the sidewalk. In this case, field-set black stone at the base acts as a cover plate to conceal the joint of foundation and precast panels. For the rest of the building, stone veneer was used as window surrounds and medallion details of a feature stone higher up, applied one per panel. While these could have been either field-set or prefabricated, it was much easier to cast them in the plant.

Wellpoint Executive Center is an 88,000-square-foot, two-story building housing the executive offices for this Fortune 500 health services corporation. In contrast to the pink stucco structures common to the area, the new executive center was designed to blend harmoniously into the stony Southern California hilltop.

Located on the last "buildable" hilltop in Thousand Oaks, the design uses two materials—sandstone and precast—to create a strong horizontal rhythm. But it changes slightly as it moves up to the predominantly precast second story. The contrast of the materials breakdown the mass of the long, low façade, so when it is viewed from a distance, the building becomes an extension of the landscape.

It was neither aesthetically nor economically suitable to build the entire façade of stone. Therefore, the design combines natural stone veneer panels with richly colored and textured precast panels to create a modern yet timeless building well grounded on its site. In addition to wanting to emphasize the aesthetic strengths of stone veneer, the company also needed to minimize costs without sacrificing design integrity. Using an innovative assembly technique, the precast contractor not only fabricated the precast panels but also mounted smaller stone



Stone veneer at the base of the 1700 Seventh Ave. building in Seattle adds an appropriate contextual detail.

panels to precast panels to form a larger, stone-faced precast unit. This resulted in a more cost- and time-effective construction solution and a highly integrated building enclosure.

After extensive research, the designers found a contextually compatible, warm buff-colored sandstone. The precast panels were custom-matched to the natural sandstone in both color and texture. Further research resulted in the choice of a warm-colored matrix and an aggregate of yellows, tans, creams and some black that picks up the variegated colors of the stone, as well as the surrounding landscape. Also, the addition of aggregate to the concrete and a medium sandblasted finish balance the precast to the stone in texture.



As these examples indicate, stone veneer provides a striking façade treatment that meets the tight restraints of today's budgets and timetables. Blending stone and precast offers a strong choice that designers should consider whenever they are looking for ways to create this type of look and to do it in a way that is both time-saving and cost-effective. 

—Jim Rothwell, AIA, principal, Callison Architecture Inc., Seattle

Faced with snowy conditions on Chicago streets, this department store uses a dark granite veneer base to provide a durable, easily maintained surface.



This detail view shows stone veneer on precast that was used as a window surround.

Additional Projects Illustrating Stone Veneers



Arizona red sandstone, 3 cm to 1³/₄ inch thick, was anchored to 4 inch thick concrete panels for the Sacramento Municipal Utility District's Customer Service Center, Sacramento, Calif. (Architect *Williams + Paddon Architects & Palnners, Inc.*)



Black granite 8 inch square accents were used on the Munsell II office building in Alpharetta, Georgia. (Architect *Harris-Fritz Architects*)



Hospital Corporation of America's Data Center, Nashville, Tenn. has 1 inch thick marble on a 5 inch precast concrete backup. (Architect *Gresham, Smith and Partners*)



The new wing for the Joslyn Art Museum, Omaha, Neb. has 3 cm marble with 6³/₄ inch concrete backup. (Architects Sir Norman Foster and Partners; Architect of Record: Henningson, Durham & Richardson, Inc.)



388 Market Street building in San Francisco, Calif. is clad with 3 cm granite anchored to precast concrete. (Architect Skidmore Owings & Merrill)



NBC Tower at Cityfront Center, Chicago, Ill. has 2 or 2³/₄ inch thick limestone on 5 inch thick precast concrete backing. (Architect Skidmore, Owings & Merrill)



Panels on the Shriners Hospital for Crippled Children, Sacramento, Calif. are 6 inch thick and have a horizontal band of 3 cm granite attached with one anchor per 2 sq. ft. (Architects Odell Associates; and Associate Architect: HDR)



Marble faced precast concrete fins are 3 x 6 feet x variable length.



Intermediate panels are 5 feet 10 inches x 1 feet 4 1/2 inches x variable length.



The base structure of the Portland Oregon Temple for the Church of Jesus Christ of Latter Day Saints, Lake Oswego, Oregon consists of 3 cm marble facing backed with 4 inches of precast concrete. (Architects *Lee, Ruff, Stark Architects; and Leland Gray Architects*)



designer's notebook



Precast/Prestressed Concrete Institute
200 West Adams Street | Suite 2100 | Chicago, IL 60606-5230
Phone: 312-786-0300 | Fax: 312-621-1114 | www.pci.org