



Precast/Prestressed Concrete Institute

Behavior of Architectural Precast Panels in Response to Drift



designer's notebook

Behavior of Architectural Precast Panels in Response to Drift

Introduction

The effects of an earthquake on architectural precast cladding come from two actions. First, the inertia of the panels develop forces due to the acceleration of their mass. Second, the horizontal movement of the building structure from lateral drift imposes forces through the connections. The performance of cladding systems depends on the interaction between the cladding and building structural frame during a seismic event.

Building Motion

Most of a building's mass is concentrated at the floor levels. During a seismic event, the building's structure transmits forces generated by the floors down to the foundation. The flexibility of the structure determines how much each floor moves. Seismic motions occur in both directions on all three axes. Seismic effects result in interstory story drift, which is horizontal movement (lateral displacement or drift) of one floor with respect to those above and below.

It is desirable to limit the amount of horizontal movement (drift) to restrict damage to partitions, shaft and stair enclosures, glass, and other nonstructural elements, and, more importantly to minimize differential movement demand on the structural elements. The limitations on interstory drift in the International Building Code (IBC), Uniform Building Code (UBC), and Minimum Design Loads for Buildings and Other Structures, ASCE 7, generally become more restrictive for the higher use building (occupancy) groups. The limits also depend on the type of structure. The design story drifts must not exceed the allowable code values, which are generally between 1% and 2% of the story height. Cladding connections for a building with a floor-to-floor height of ten feet can require up to two-and-a-half inches of movement allowance between floors.

Precast concrete panels are more rigid in-plane than out-of-plane. They may even be more rigid than the structure. The goal in configuring and connecting architectural precast cladding panels is to prevent the panel system from participating in the lateral load-resisting system of the structure. In other words, when the building moves, forces should not pass through the panels.

Precast Panel Configuration

For fabrication, handling, and erection economy, the use of the largest possible panels (subject to weight and transportation restrictions) is recommended. However, seismic requirements are often at odds with use of very large panels because of the accumulated deformations in the main structure that must be accommodated. While in non-seismic areas two- or three-story-height panels may be used, the usual practice in higher seismic zones is to use panels that are limited to one story in height and seldom more than one horizontal bay in width.

Codes require that connections and panel joints allow for the story drift caused by relative seismic displacements. Connection details, and joint locations and sizes between cladding panels, should be designed to accommodate any shrinkage, story drift, or other expected movement of the structure, such as sway in tall, slender structures. Panel geometry and joints must be configured so that panels do not collide with one another or with the supporting structure when it moves. If collisions occur, over-loading of the connections may result as well as damage to the body of the panel. Story drift must be considered when determining joint locations and sizes, as well as connection locations and their directions of resistance. If a connection can resist a force in a given direction then it can also cause panel motion in that direction.

Almost all non-structural (cladding) precast concrete panels are supported vertically at one floor only. This allows floors to deflect without transferring building gravity loads through the panel. The types of connections used to support the panel will ultimately determine the motion a panel will experience during a seismic event. Connection types are discussed in detail further on.

Panel-connection-structure interaction

The way cladding panels behave in response to displacement of the supporting structure can be summarized as shown in **Figure 1**.

In-plane translation (**Fig. 1-a**) occurs when the panel is “fixed” in-plane to one level. The panel translates laterally with that level, remaining vertical. Spandrel panels and wall panels are typically designed to behave this way.

In-plane rotation, also known as “rocking” (**Fig. 1-b**), occurs when the panel is supported in-plane at two levels of framing. When the structure displaces, the lateral connections drag the panel laterally, causing it to rotate in-plane and rest entirely on one bearing connection. This rotation requires bearing connections that allow lift-off. Narrow components such as column covers are often designed this way because of their aspect ratio (height to width) and the location of their connections.

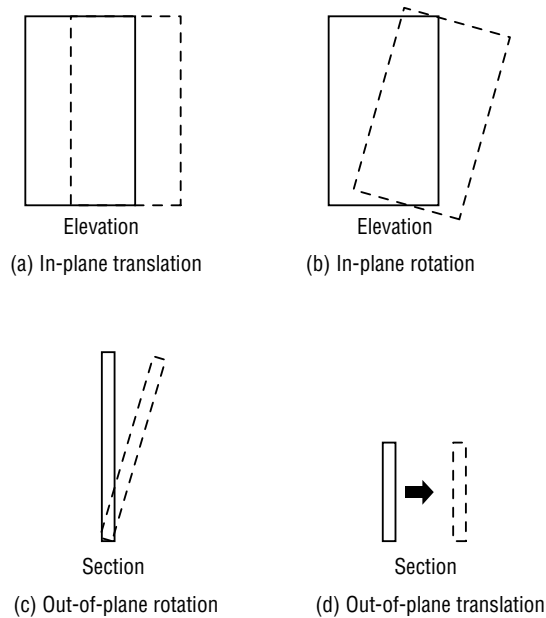

Figure 1 Modes of panel response to displacement.

Out-of-plane rotation (**Fig. 1-c**) is the tilting of a panel perpendicular to its face. This motion is common whenever a panel is connected to the structure at different levels of framing. The tie-back connections that support the panel for wind and seismic loads will also cause the panel to tilt out-of-plane during story drift. Bearing connections should be designed to accommodate this out-of-plane rotation, although it is generally so small that it is usually ignored with ductile connections.

Out-of-plane translation (**Fig. 1-d**) is common for spandrel panels that are attached to a single level of framing, since the movement is the same as the supporting member to which it is attached.

With this in mind, we will examine how each type of motion is accompanied by specific connection requirements and joint treatments.

Panels supported laterally at one floor only

Story drift is rarely an issue with spandrel panels because bearing connections and tie-back connections are located on the same floor member. The tie-backs are not affected by story drift because the top and bottom of the floor beam move together (see **Fig. 2-b**). Therefore, all panels connected to a given level will move with that level. The panels respond to building displacement as shown in **Figure 1-a** because they are supported in-plane at one level only and **Figure 1-d** because they are supported out-of-plane at one level only. Vertical panel joint

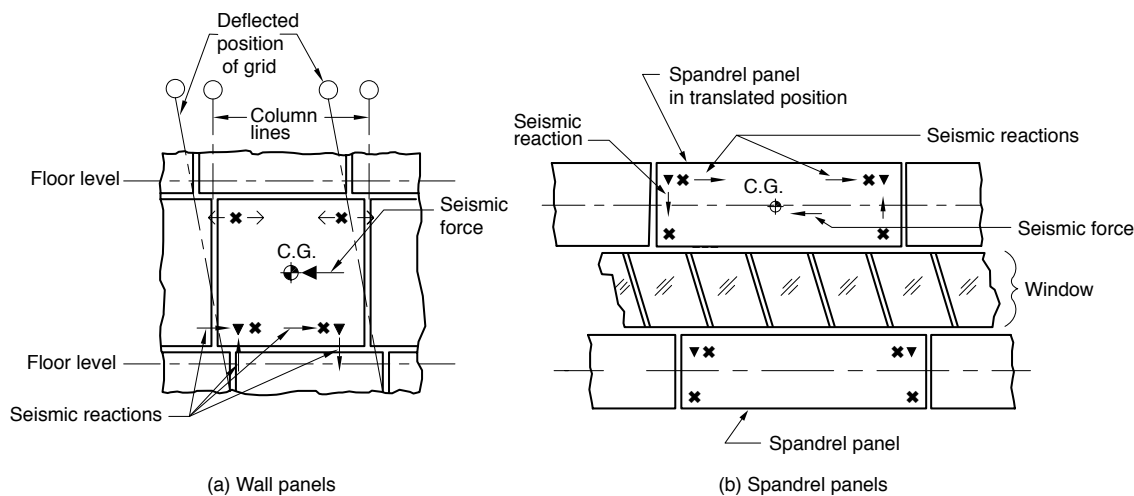

Note: Gravity and out-of-plane loads to connectors not shown; C.G. = center of gravity

▼ Bearing connection
 ✕ Tie-back connection
 ← Allowed movement direction

Figure 2 Cladding panel connection concepts—Seismic drift effect (Translating panels)—low aspect ratios.

widths can be kept to a minimum because there is no differential movement between panels and connections need only accommodate small movements from shrinkage or temperature changes.

Panels supported at two levels of framing

When a panel is arranged such that it requires out-of-plane support from two levels of the structure, its connection system can make the panel rotate in-plane or translate without tipping or rocking (**Figs. 2 and 3**). It is essential that the potential movements be studied and coordinated with regard to the connection system and the joint locations and widths as well as adjacent construction. Such considerations often govern the connection design or the wall's joint locations and widths. The following discussions will address each type of motion in detail.

Panels connected out-of-plane at two levels and in-plane at one level (Translating)

Connections that resist imposed loads in all directions are referred to as rigid or fixed connections. Rigid bearing connections are generally used in panels that translate in-plane as shown in **Figure 1-a**. Fixed bearing panels are vertical cantilevers in the in-plane direction. The two bearing connections resist the direct in-plane seismic force, as well as the

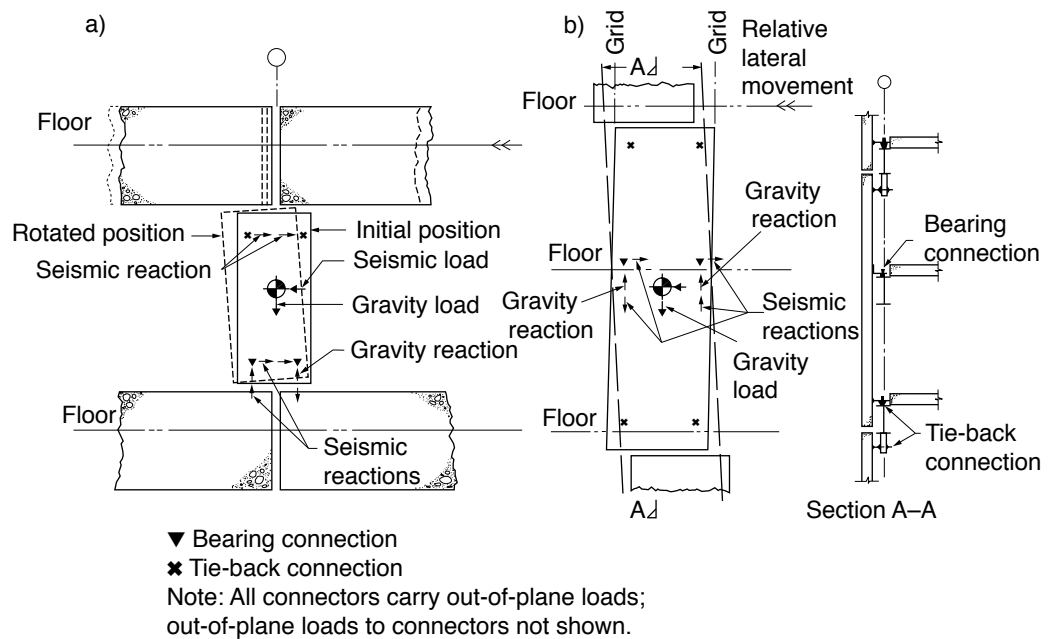

Figure 3 Tall/narrow units—high aspect ratios.

resulting overturning moment. The moment is resisted by a couple formed by the bearing connections. When combined with panel self-weight, the tie-down forces may result in a net uplift on one connection and added downward force on the other. The bearing connections hold the panel down and prevent it from tipping (**Fig. 4-a**).

The upper tie-back connections, or “slip connections,” that allow horizontal and vertical movement of the panel relative to the supporting structure (**Fig. 4-c**), must only resist out-of-plane forces. If they were to resist in-plane forces, then they would also transmit in-plane movement. This would create a tug-of-war between the structure and the rigid bearing connections. These connections should be flexible or slotted in-plane to allow the structure to drift without over loading the connection. The panel will translate with the level of framing that the rigid bearing connections are attached to, and will remain vertical through this translation.

Proper orientation and length of slotted inserts are necessary but not always sufficient to allow movement without binding. This is especially true if the connection parts are in compression against the connection body, or have high tensile forces that result in large friction forces against the fastener as slippage may be restricted. Corrosion protection of these sliding connections should also be considered to ensure their long-term performance so the sliding effect can occur without binding.

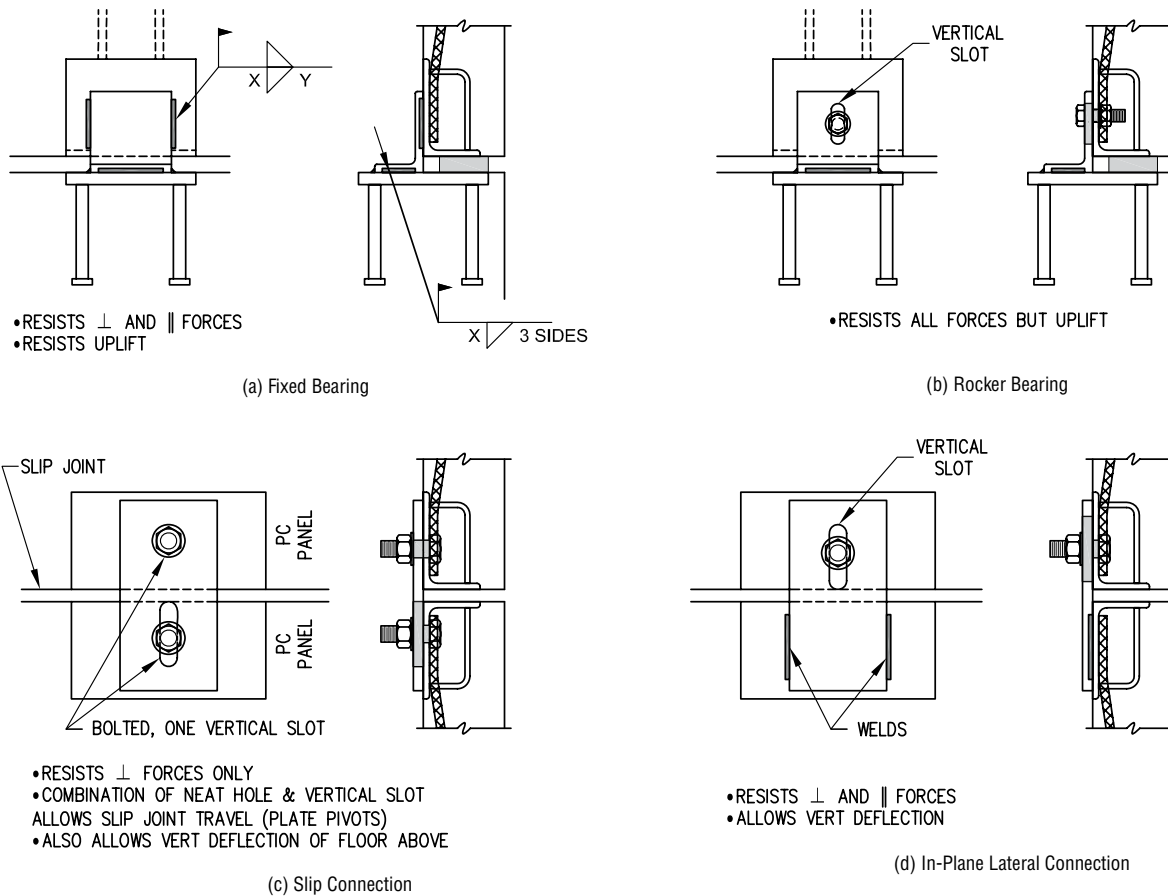

Figure 4 Four basic seismic connection types.

Flexible connections must have ample rod or plate length to truly bend and flex under drift without failing. All components of the connection system must be designed to allow either bending or sliding within the connection with slotted or oversized holes. The bottom connections will also have to be designed to handle the force that it takes to yield the upper connections. Careful installation and inspection are required to ensure that construction tolerances do not negate the available movement in a way to make the connection ineffective.

When panels are designed to translate, the horizontal joint at each level should remain at a constant elevation whenever possible, as it tracks around the perimeter of the building. This will permit the panels attached to one floor to move with that floor's drift relative to the panels above and below them. Elevation changes (**Fig. 5**) will require seismic joints at the transitions and detract from the aesthetics of the cladding.

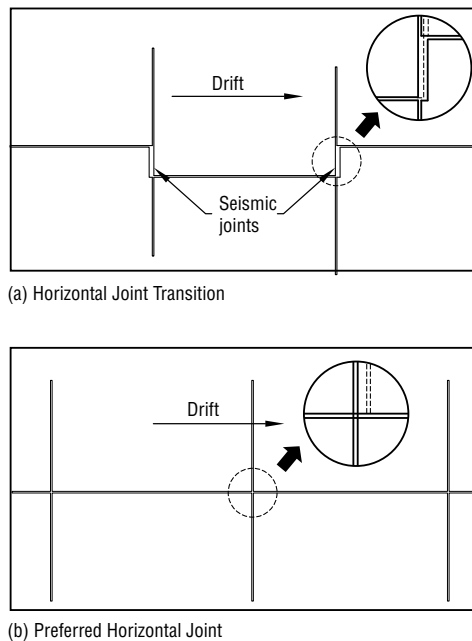

Figure 5 Joint elevation changes.

A common way to avoid panel collisions is to increase the joint width, positioning the adjacent panel beyond the limit of movement. A common case is shown in **Figure 6**, where wall panels form the corner of the building. Wall panels are typically connected at two framing levels and consequently rotate out-of-plane in response to structure drift. In the case of a corner, building motion will be perpendicular to one panel while being parallel to another, resulting in the joint between the two panels either opening or closing up. To avoid a collision, at outside corners the corner joint width must be increased relative to the magnitude of drift. Mitered panels may be used to reduce the width of the seismic joint required in this situation.

Panels connected out-of-plane at two levels and in-plane at two levels (Rocking)

Bearing connections that allow vertical upward movement (lift-off) may be referred to as rocker connections. This type of connection would allow the panel to rotate in-plane as shown in **Figure 4-b**. Rocking panels are vertical, in-plane simple spans. The upper connections must provide in-plane as well as out-of-plane support for the panel. The applied seismic force is resisted by horizontal reactions in the bearing connections and the upper lateral connections. The lower (bearing) connections must allow lift-off. The simple-span reactions provide overturning stability, so there is no need for the bearings to resist tie-down forces (drift compatibility prohibits this).

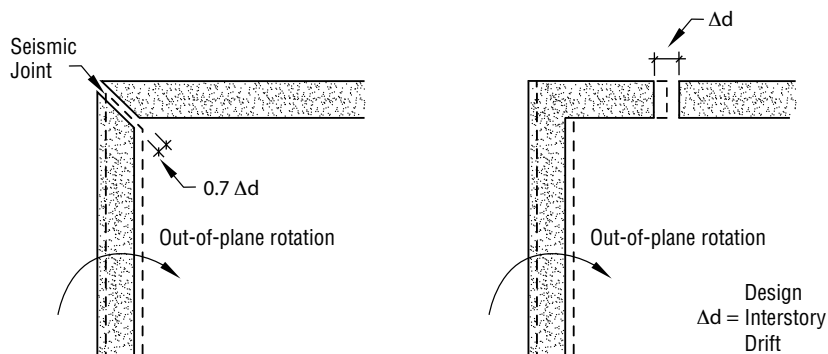

Figure 6 Corner joint made wider to avoid collision.

In **Figure 3-a** connections with in-plane and out-of-plane restraint at the top of the panel, together with lift-off allowance at the bottom connections, force the panel to rock when subject to building drift. Its entire weight is then being carried on one lower bearing connection. Because the movement occurs in both directions, each bearing connection must have the capacity to carry the full weight of the element and allow lift-off.

The bearing connections as well as the upper lateral connections must provide freedom for vertical motion of the panel as it rocks (see **Figs. 4-b** and **4-d**). The same rules apply as for the horizontal slots or yielding connections in the translating panels above, but in this case, the slots would be vertical.

The possible area for panel collisions now is no longer at the corners of the building because both panels are rocking in the same direction. The horizontal joint is at the top of the panel. It will open and close as the panel lifts up. One way to minimize vertical motion is to set the bearing connections closer together. Otherwise, the horizontal joint size may need to be increased.

How to choose between the two types of motion

A panel whose aspect ratio is small (height is similar to or significantly smaller than its width) is best designed for in-plane translation. If the panel were designed with rocking bearing connections and allowed to rotate, the upper horizontal joint would have to be sized to allow for large vertical movement of the panel. Depending on the specific geometry, this horizontal joint width could become quite large and affect the aesthetics of the cladding. More importantly, the force required to lift up the panel could easily become quite large. For these reasons, the panel should be designed to translate in-plane. The horizontal joint would be held to a nominal size and the overturning loads could reasonably be handled by taking advantage of the low aspect ratio of the panel.

Panel rotation (rocking) should be considered and rigid connections should be avoided in situations where the panels' aspect ratio is high (height significantly greater than width) because the resulting large overturning forces could become unmanageable. Instead of trying to resist the overturning force, rocker connections can be used to allow the panel to freely rotate to accommodate story drift. In this case, the bottom connections would be designed as rocker connections and the top connections would be designed as in-plane lateral connections.

Interface with adjacent finishes

Glazing systems installed in seismic areas are usually rigidly connected at the top and bottom so the window systems rock and do not translate. This condition is illustrated in **Figure 2-b**. If this window arrangement were adjacent to the rocking panel shown in **Figure 3-a**, the two systems could be compatible. If this window type is adjacent to a translating panel like the one shown in **Figure 2-a**, then a large joint or vertical crush zone on the side of the window is required to prevent breaking the window.

The window system can be designed to accommodate translation with the use of sliding connection details, but that is not the common detail. This would be advantageous when windows are adjacent to translating panels, and it would also be likely that the window system would rely on a reaction from the panel to keep it rigid. The windows would also require special consideration for sealant application.

In all cases, the precast engineer and the glazing engineer should coordinate their efforts early in the design phase to avoid conflicts.

Other configurations

If the panel that spans two floors is tall and narrow (high aspect ratio), bearing connections can be located so the unit translates with the level of the bearing connections. If they are vertically close to the panel's center of gravity, as in **Figure 3-b**, the seismic overturning couple is minimized and the bearing connections would carry all gravity and in-plane seismic loads. The tie-backs would then isolate both the top and bottom of the panel from their respective floors, (**Fig. 3-b**). An alternative seismic connection sometimes used for tall, narrow units is a single bearing connection, along with sufficient tie-backs for stability.

Connections for load-bearing wall panels are an essential part of the structural support system, and the stability of the structure may depend on them. Load-bearing wall panels may have horizontal and/or vertical joints across which forces must be transferred. Load-bearing panel connections should be designed and detailed in the same manner as connections for other precast concrete structural members. It is desirable to design loadbearing precast concrete structures with connections that allow lateral movement and rotation, and to design the struc-

ture to achieve lateral stability through the use of floor and roof diaphragms and shearwalls. Designers are referred to an extensive treatment of design methods in the *PCI Manual on Design and Typical Details of Connections for Precast and Prestressed Concrete* and the *PCI Design Handbook*. 



designer's notebook



Precast/Prestressed Concrete Institute
200 West Adams Street | Suite 2100 | Chicago, IL 60606-5230
Phone: 312-786-0300 | Fax: 312-621-1114 | www.pci.org